

CABINET MOUNTING HOLES

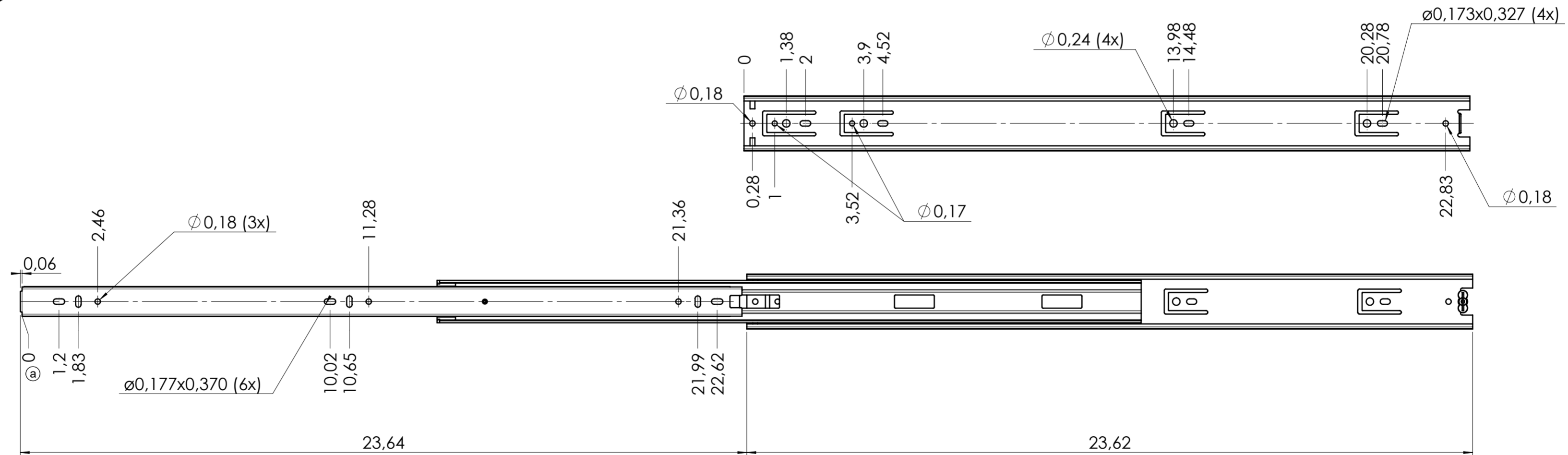

RECOMMENDED HARDWARE:
 CABINET- 3.5mm SPAX M4 BUTTON HEAD OR #8 TRUSS HEAD SCREW
 DRAWER- 3.5mm SPAX M4 BUTTON HEAD OR #8 TRUSS HEAD SCREW

general tolerances		DIN ISO 128-30	
stamping part according Fulterer W18-001	plastic part according DIN ISO 16742 TG4	missing dimensions see 3D	
This drawing remains our property and may not be multiplied neither be disclosed to third parties (§§1,3 and 5 from the copyright Act (UrhG))		= theor. intersection	
covered according to DIN ISO 16016		scale: 1:3	surface: A2
(k)		date	name
(l)		drawn 12-05-2021	MW
(m)		proven 00-00-0000	00
(n)		Fulterer	
(o)			
(p)		Fulterer AG & Co KG	
(q)		A-6890 Lustenau / Austria	
(r)		Fulterer AG	
(s)		CH-9430 St. Margrethen	
(t)	adj. dimensional reference	23-11-2022	BM
(u)	changes	date	na.
description: SIDE MOUNT FULL EXTENSION DRAWER SLIDE WITH DRAWER DISCONNECT		drawing number: 5046.600-GA.C200A	
		replaces version date:	