

5210.550-GA.T106

X

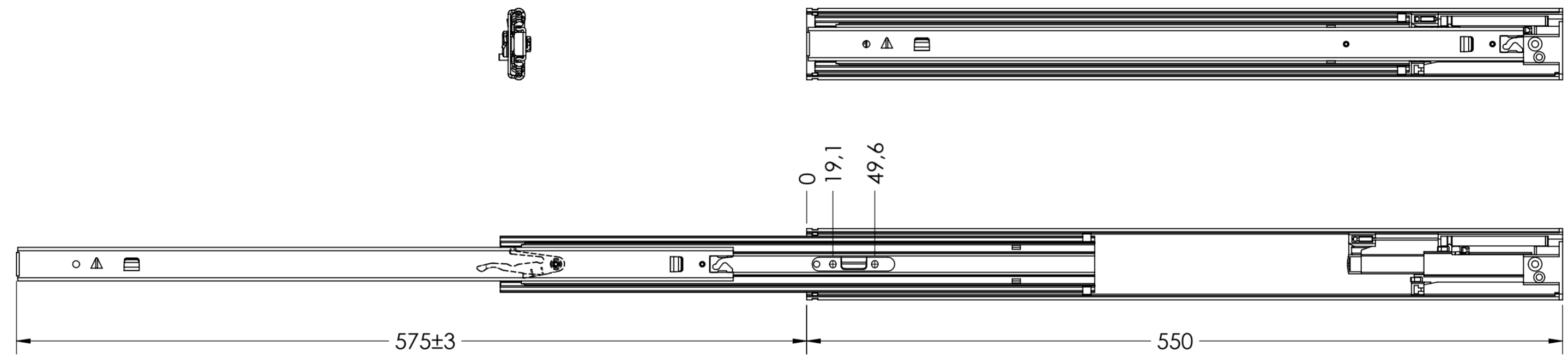
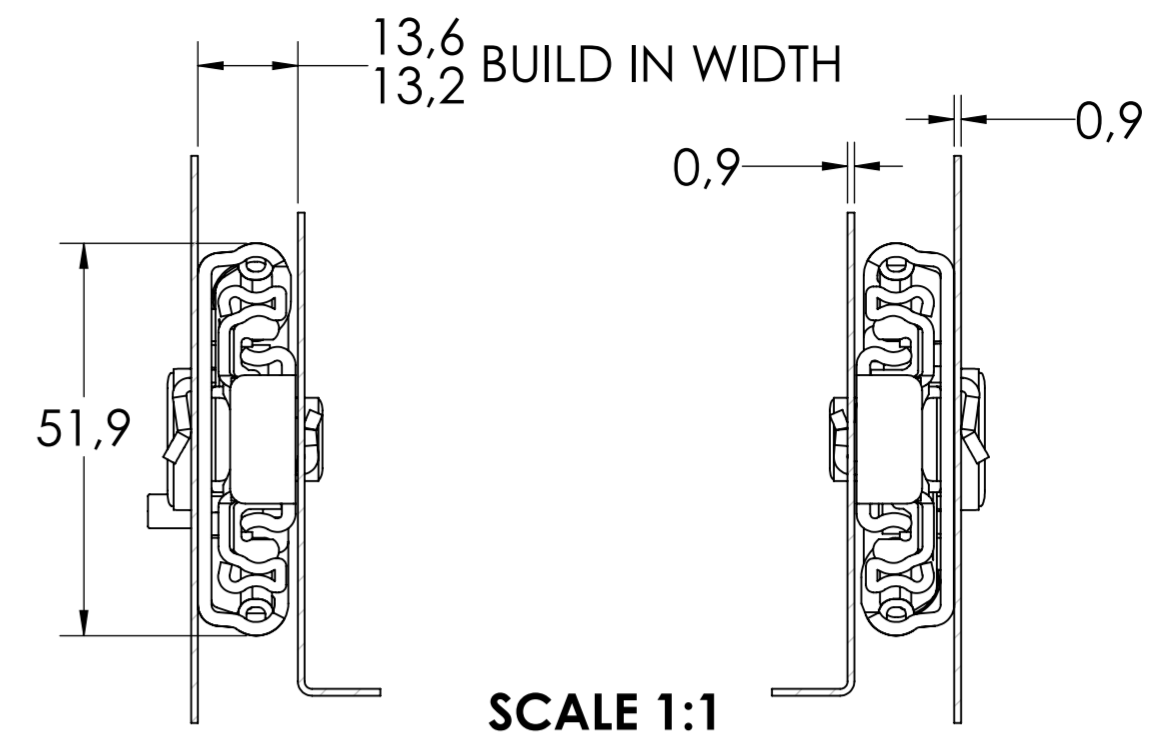
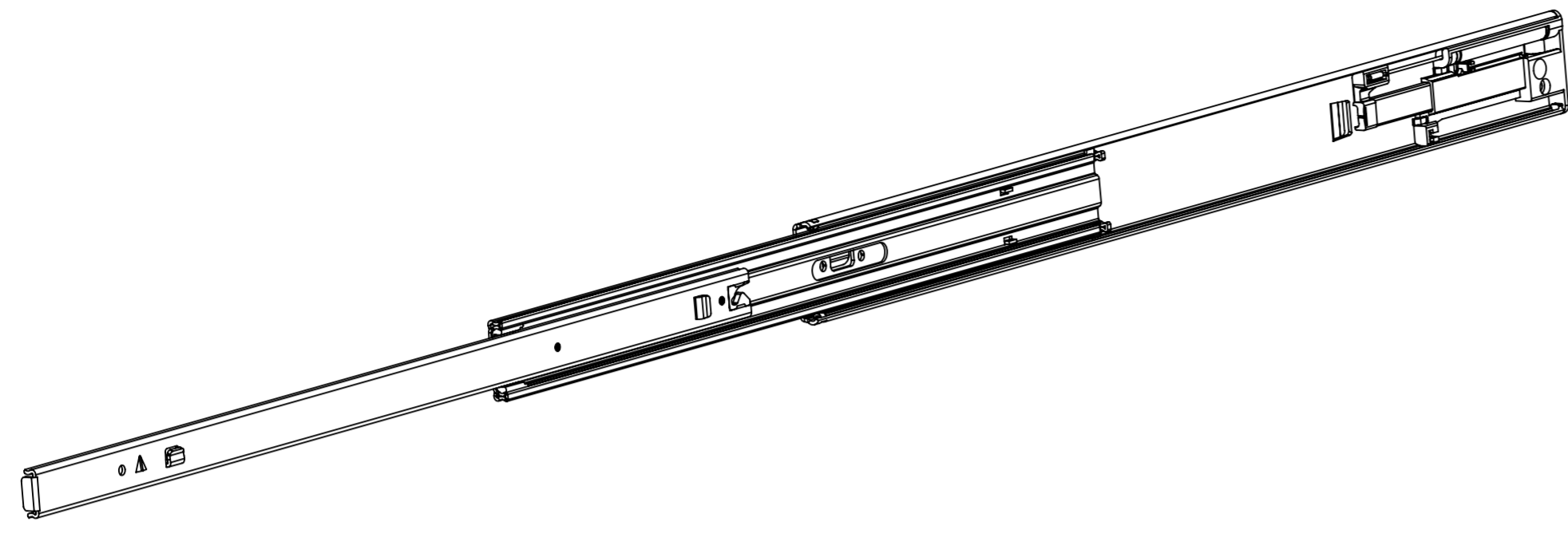

DRAWER MOUNTING CUTOUTS

CABINET MOUNTING CUTOUTS

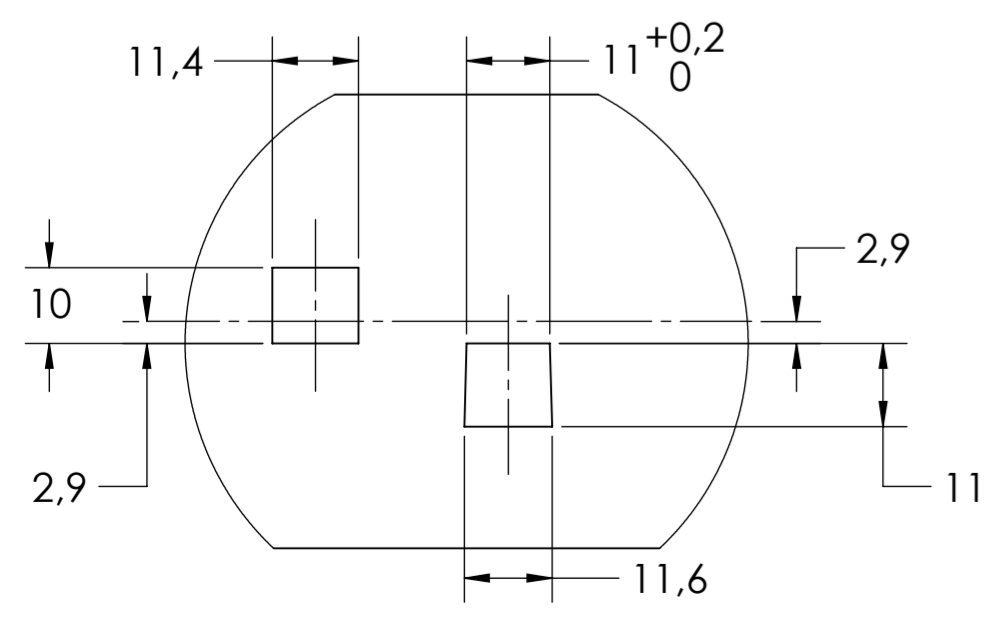
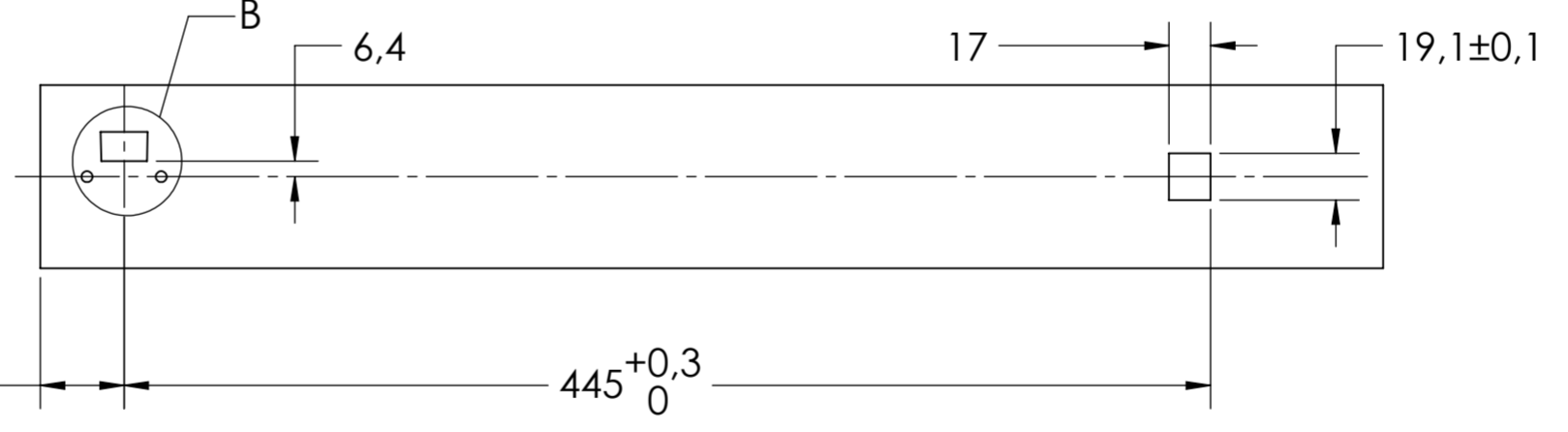
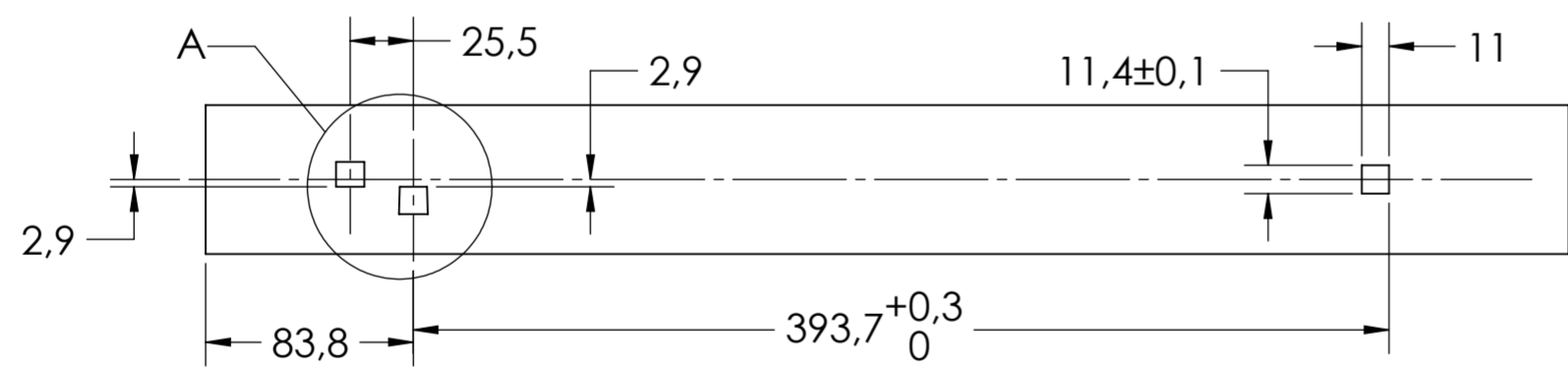

DETAIL A
SCALE 1:1

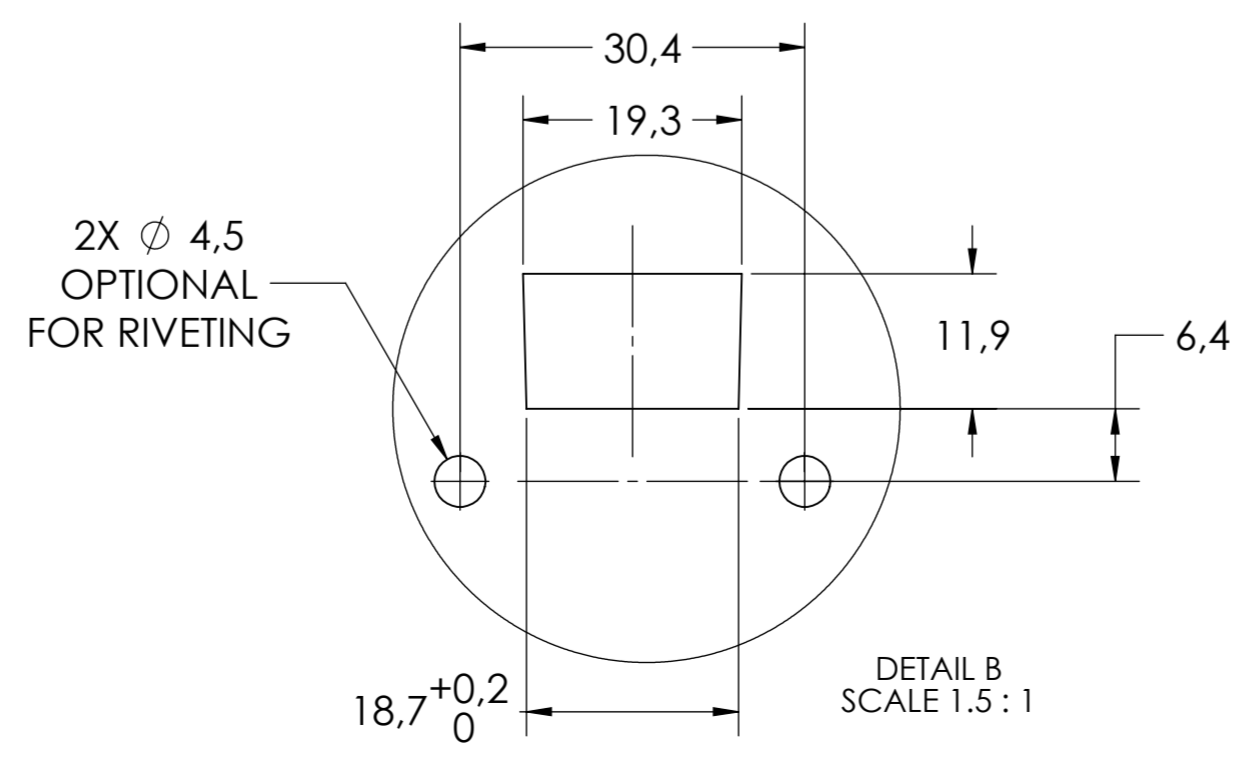

DETAIL B
SCALE 1.5:1

PULL OUT FORCE: 24N ± 2N (5.4 lbf. ± 0.5 lbf.)

general tolerances		DIN ISO 128-30 missing dimensions see 3D = theor. intersection	
ISO 2768-m			
This drawing remains our property and may not be multiplied neither be disclosed to third parties (§§1,3 and 5 from the copyright Act (UrhG)) covered according to DIN ISO 16016			
scale: 1:3		surface: A2	
drawn: 14-06-2019		name: HB	
proven: 00-00-0000		00	
		material, semi finished parts: STEEL (technical requirements Fulterer)	
		description: SIDE MOUNT OVER EXTENSION SMT (0.9) SLIDE WITH SOFT CLOSE & DRAWER DISCONNECT	
drawing number: 5210.550-GA.T106		replaces version date:	
ind.	changes	date	na.