

5210.700-GA.T106

X

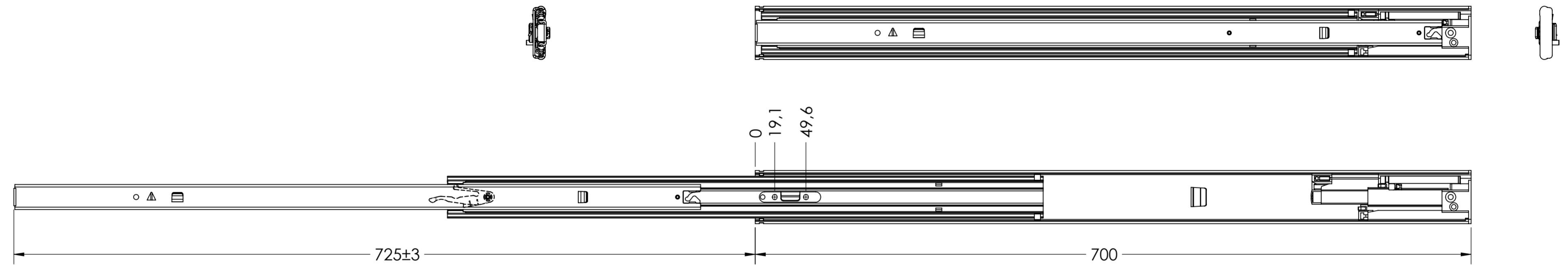

DRAWER MOUNTING CUTOUTS

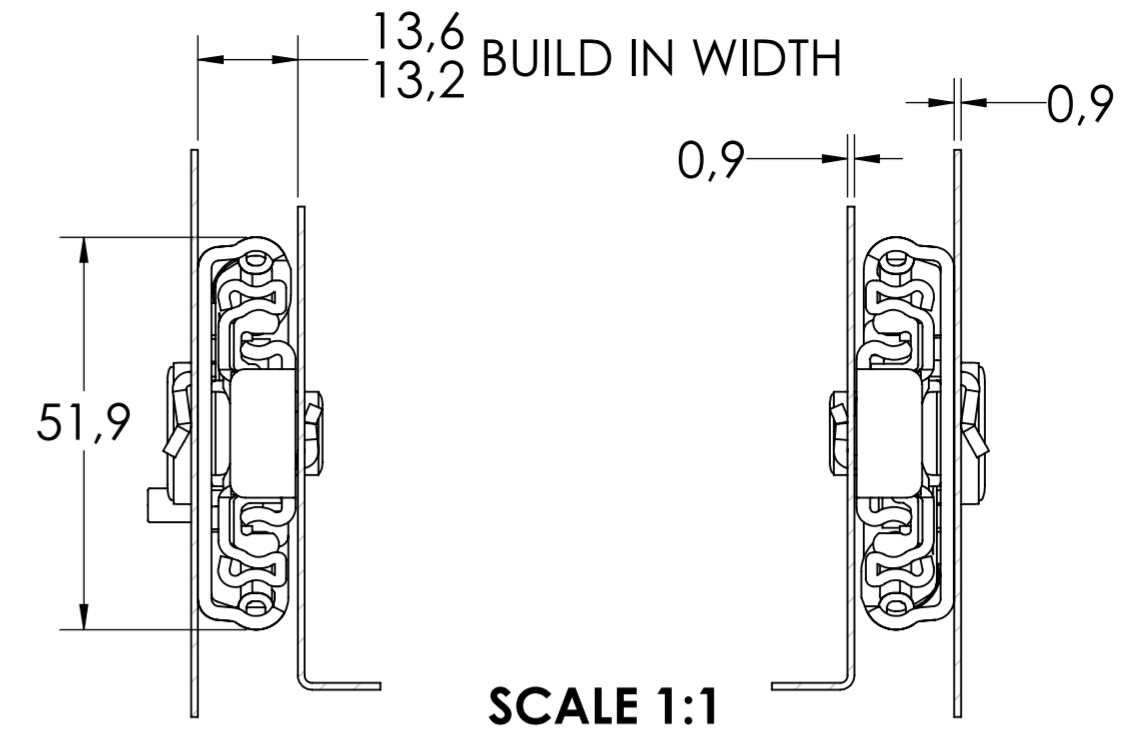
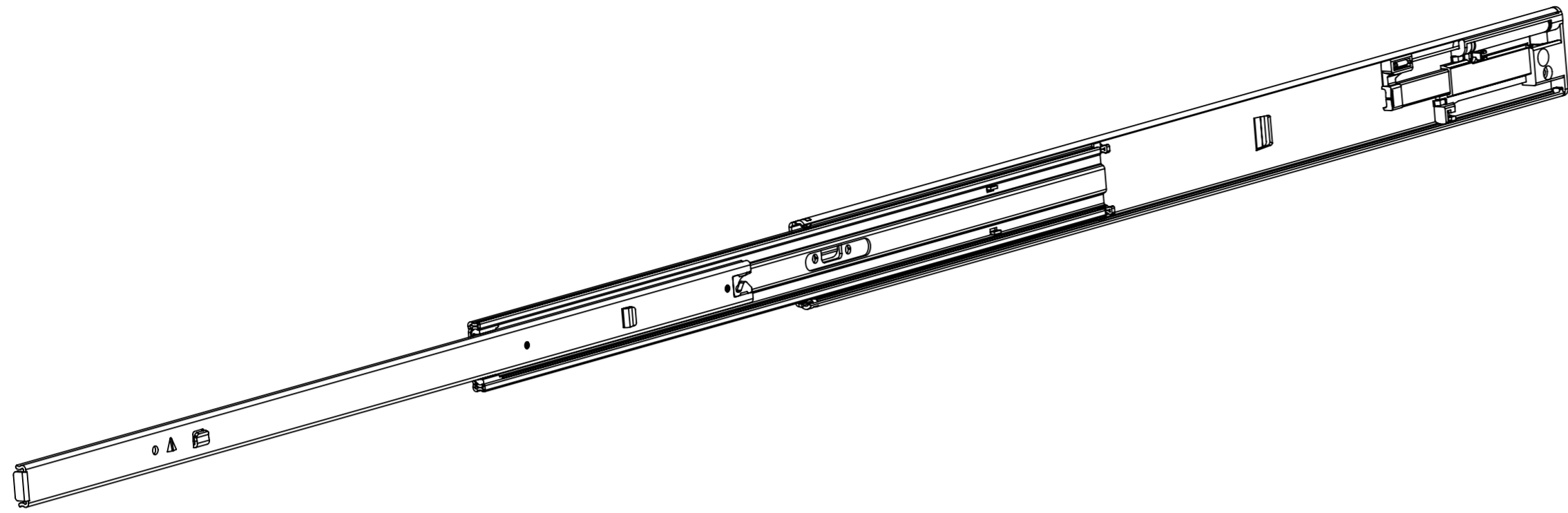
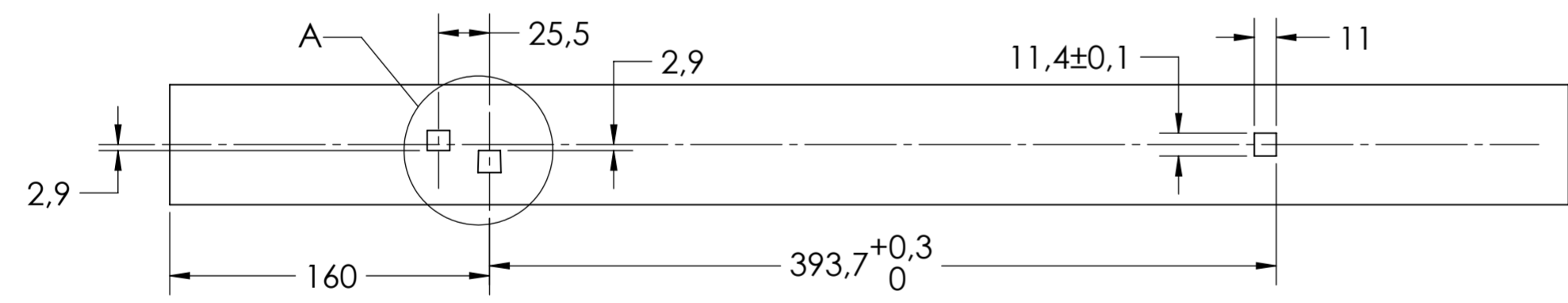

CABINET MOUNTING CUTOUTS

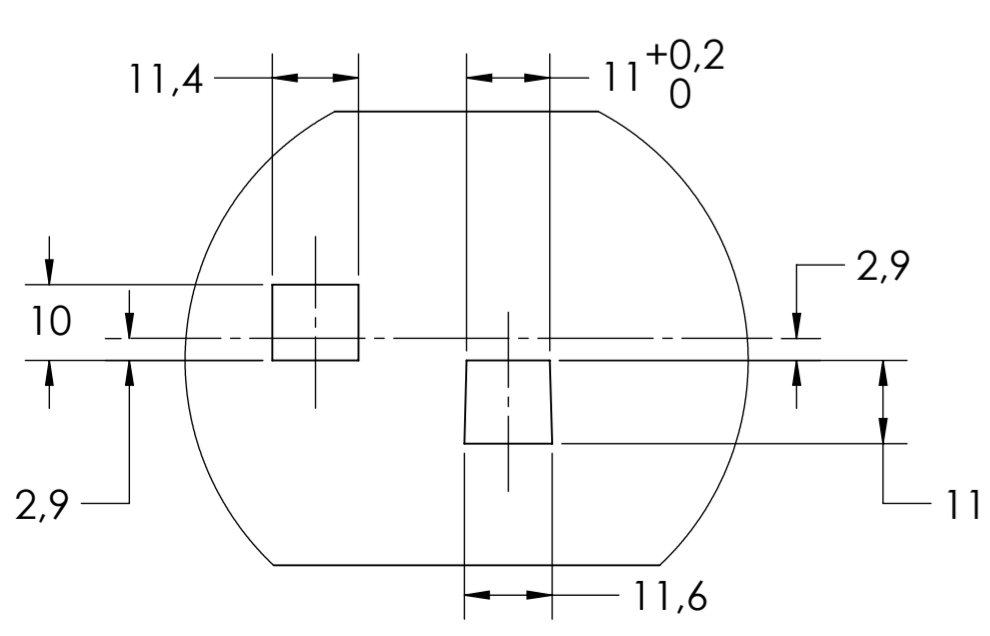
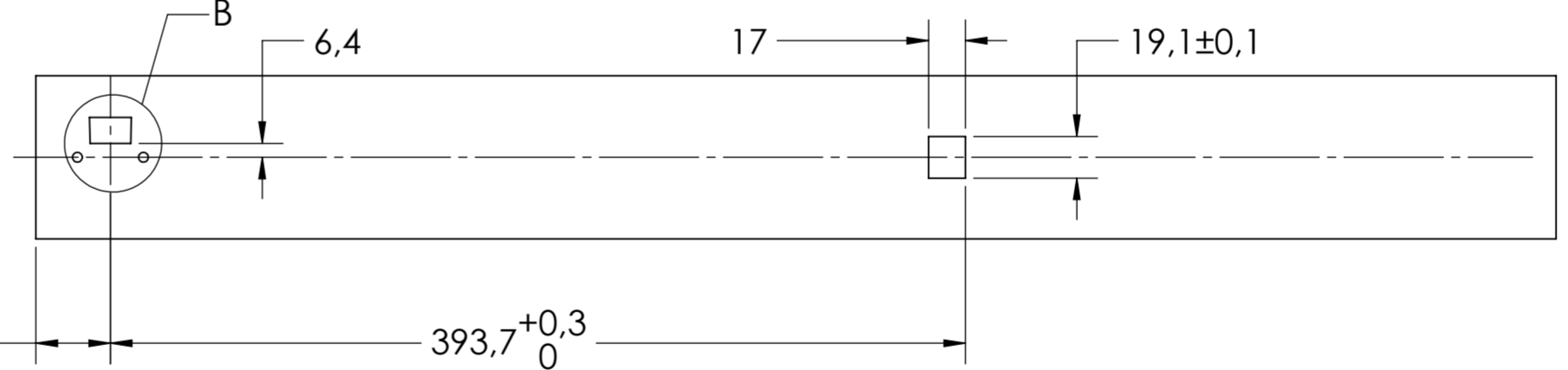

DETAIL A
SCALE 1:1

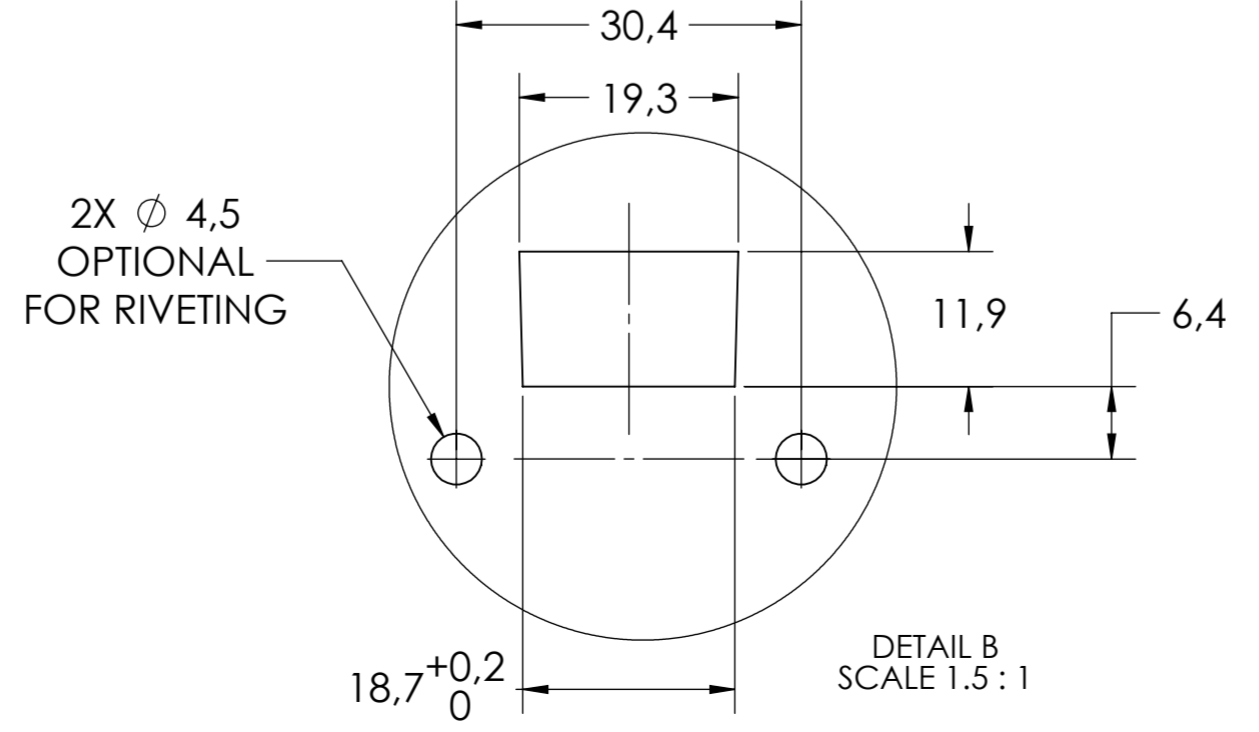

DETAIL B
SCALE 1.5:1

PULL OUT FORCE: 24N ± 2N (5.4 lbf. ± 0.5 lbf.)

general tolerances		DIN ISO 128-30 missing dimensions see 3D = theor. intersection	
ISO 2768-m			
This drawing remains our property and may not be multiplied neither be disclosed to third parties (§§1,3 and 5 from the copyright Act (UrhG)) covered according to DIN ISO 16016			
(k)	scale:	1:3	surface:
(l)	date:	14-06-2019	name:
(m)	drawn:	HB	
(n)	proven:	00-00-0000	00
(o)	Fulterer		material, semi finished parts:
(p)			STEEL
(q)			(technical requirements Fulterer)
(r)			description:
(s)			SIDE MOUNT OVER EXTENSION
(t)			SMT (0.9) SLIDE WITH SOFT
(u)			CLOSE & DRAWER DISCONNECT
(v)			drawing number:
(w)			5210.700-GA.T106
(x)			replaces version date:
(y)	ind. changes	date	na.
(z)			